









A high-contrast, black and white photograph showing a close-up of the internal components of a gear pump. The image features several interlocking metal gears and shafts, with bright highlights reflecting off their surfaces against a dark background. Two thin white diagonal lines cross the image from the top left to the bottom right.

LO
BOMBAS DE ENGRANAJES
GEAR PUMPS

Roquet
making moves

Empresa	3
Información general	4
Bomba de engranajes L0 	
Datos técnicos	5
Sistema de codificación.....	7
Tipos de ejes motriz.....	8
Tipos de conexión tomas.....	8
Tipos de tapas frontales	9
Tapa tipo 01	10
Tapa tipo 09	11
Tapa tipo 10	12
Tapa tipo 22	13
Tapa tipo 27	14
Bomba de engranajes LQ (L0+L0) 	
Tapa tipo 10	15
Bomba de engranajes LP (L0+M) 	
Tapa tipo 10	16
Otras opciones 	
Bomba de engranajes L0F.....	17
Conexión con tomas T.....	18
Tapa trasera para bombas reversibles.....	18
Tipos de polea	18
Bomba con válvula limitadora.....	19
Bomba con válvula de aspiración - retención	20
Recambios	
Bomba L0 / L0F	21
Bomba LQ (L0+L0).....	22
Bomba LP (L0+M).....	23

Company	3
Information	4
Gear pump L0 	
Technical data	5
Coding system	7
Drive shaft forms	8
Port connection forms	8
Front flange types	9
Front flange type 01	10
Front flange type 09.....	11
Front flange type 10.....	12
Front flange type 22.....	13
Front flange type 27.....	14
Gear pump LQ (L0+L0) 	
Front flange type 10.....	15
Gear pump LP (L0+M) 	
Front flange type 10.....	16
Other options 	
Gear pump L0F.....	17
Port connection form T.....	18
Back cover for reversible pumps.....	18
Types of pulley	18
Pump with relief valve	19
Pump with check valve	20
Spare parts	
Gear pump L0 / L0F.....	21
Gear pump LQ (L0+L0)	22
Gear pump LP (L0+M).....	23

HISTORIA Más de medio siglo de trayectoria especializada en oleodinámica. Roquet es proveedor internacional en los sectores agrícola, naval, manutención, máquina-herramienta, automoción pesada, maquinaria de obras públicas, minería, eólica, alimentación, etc. Marca líder en España y una referencia importante en el ámbito internacional.

TECNOLOGÍA Roquet dispone de un importante departamento de diseño y desarrollo, con bancos de prueba de fatiga, nivel sonoro, resistencia a la corrosión, etc, apoyados por un avanzado laboratorio metalográfico. Se realizan grandes inversiones en centros de mecanizado de última generación para mantener una óptima calidad-productividad. La mayoría de piezas críticas (correderas, piezas de fundición, ejes de bomba, etc) se fabrican íntegramente en la propia empresa.

FIABILIDAD Una extensa gama de productos robustos y resistentes. Diseñados para rendir, contruidos para durar. Todas las gamas de productos se someten a pruebas de vida en condiciones de trabajo realistas durante el diseño y desarrollo del producto. De esta forma se asegura su perfecta adaptación a las diversas aplicaciones finales tales como tractores, carretillas elevadoras, palas cargadoras, excavadoras, grúas, volquetes, muelles de carga... Se prueba el 100% de las unidades producidas, según procedimientos internos de prueba, antes de la expedición.

CAPACIDAD 400 profesionales en plantilla. Cinco plantas de producción con una superficie cubierta de 40.000 m². Producción actual: 180.000 bombas, 300.000 cuerpos de distribuidor y 500.000 cilindros. Una red comercial de distribución extendida por más de 35 países de los 5 continentes.

HISTORY Over fifty years experience in fluid power. Supplier to international manufactures of agricultural, construction, mining, mechanical handling, machine-tool and food machinery. Main supplier to the Spanish market with rapidly increasing presence in European and world markets.

TECHNOLOGY Roquet has a large design and development department with substantial fatigue, noise, corrosion-resistance, cleanliness and testing facilities, backed by a well-equipped metallurgical laboratory.

RELIABILITY A broad range of robust products: designed to perform, built to last. All products ranges life-tested under realistic conditions during development to ensure their suitability for use in applications such as tractors, fork-lift trucks, loaders, excavators, cranes, dumpers, dock-levellers... Each and every product tested to a stringent test specification prior to shipment.

CAPABILITY 400 well trained employees. Five factories with a total floor area of 40.000m² Current production 180.000 pumps, 300.000 control valve bodies and 500.000 cylinders. Distribution network in over 35 countries.

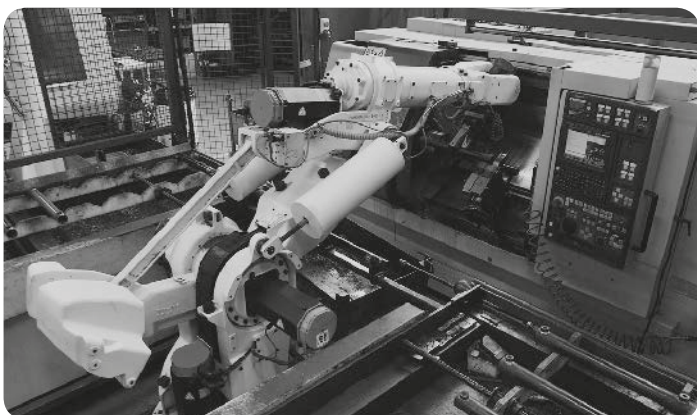
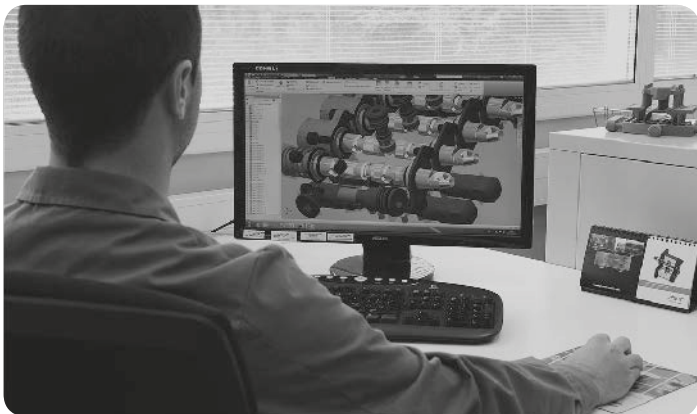

Nuestras bombas están equilibradas hidrostáticamente y provistas de reajuste lateral automático.

Se recomienda el empleo de aceite para instalaciones oleodinámicas con aditivos antiespumantes y de extrema presión.

Para obtener una larga vida, tanto del aceite como de la bomba es preciso trabajar entre una viscosidad de 20 - 80 cSt, según presiones de trabajo a una temperatura de 50° C.

Gama de temperaturas del fluido hidráulico +5° C +80° C.

El apartado de filtraje es muy importante, ya que la mayoría de averías son debidas a la suciedad del aceite. Ver datos técnicos.

La mejor forma de accionamiento es de conexión directa por medio de un acoplamiento elástico, que permite un movimiento mínimo radial y axial de 0,3 a 0,4 mm, por lo que de esta forma quedarán absorbidas todas las vibraciones del motor que tanto perjudican la buena marcha de la bomba. Los conductos de aspiración serán lo suficientemente dimensionados para que la depresión no exceda de 0,3 bars. Conexión por bridas S.A.E. o rosca G.

Sentido de giro derecha o izquierda, mirando la bomba por el lado del eje. Antes de poner por primera vez la bomba en marcha, asegurarse que el sentido de giro es el correcto.

Presentamos en el apartado de bombas dobles, varios tipos de fijación con sus ejes más normales. No obstante se podrán construir bombas dobles con las mismas fijaciones que las simples y sus ejes correspondientes.

Estas consideraciones también son validas para bombas triples y cuadruples, que podemos fabricar.

NOTA IMPORTANTE: En versión estándar la conexión es de rosca G.

Este catálogo muestra los productos en su configuración más estándar. Para diseños personalizados o especiales, deberá ponerse en contacto con ROQUETHYDRAULICS, S.L.

Las especificaciones y los datos de este catálogo no son susceptibles de interpretación. En caso de dudas, póngase en contacto con ROQUETHYDRAULICS, S.L.

ROQUETHYDRAULICS, S.L. se reserva el derecho de realizar modificaciones, actualizaciones o revisiones de este catálogo sin previo aviso.

ROQUETHYDRAULICS, S.L. no es responsable de ningún daño provocado por un uso incorrecto del producto.

Our pumps are hydrostatically balanced and have automatic lateral adjustment.

We recommend the use of the oil for oil-dynamic installations with antifoaming additives and for extreme pressure.

To obtain extended pump life it is necessary to work with oil viscosities between 20 - 80 cSt, relating to working pressure and at a temperature of 50°C.

Oil temperature range +5°C - +80°C.

Filtration is extremely important since most problems are due to oil contamination.

The most efficient drive method is by means of axial flexible coupling, with minimum 0,3 - 0,4 mm. radial and axial movement, thus reducing the effects of vibration and maintaining maximum efficiency of the pump.

The suction pipes should be large enough to ensure that cavitation does not exceed 0,3 Bar. Connection by SAE flange or threaded G.

Rotation direction: Clockwise or anti-clockwise when facing the shaft end.

Before starting the pump, make sure the direction of rotation is correct.

Double and multiple pumps are available with all shafts and flanges shown for single pumps.

IMPORTANT NOTE: Side ports threaded G are available as standard version.

This Catalogue shows the product in the most standard configuration; customized or special designs are also available, please contact to ROQUETHYDRAULICS, S.L.

The specifications and data in this catalogue are not open to any interpretation, please contact with ROQUETHYDRAULICS, S.L. in case of doubt.

ROQUETHYDRAULICS, S.L. reserves the right to modify, update or revise this catalogue without prior notice.

ROQUETHYDRAULICS, S.L. is not responsible for any damage caused by an incorrect use of the product.

Partes de una bomba / Pump parts

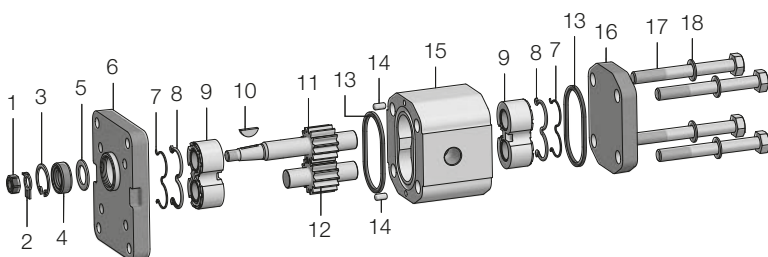

1	Tuerca Nut	10	Chaveta Key
2	Fijador tuerca Safety washer	11	Rueda motriz Drive shaft
3	Anillo elástico Circlip	12	Rueda conducida Driven shaft
4	Retén aceite Oil seal	13	Junta de tope Housing gasket
5	Arandela tope retén Shaft seal end ring	14	Pasador Pin
6	Tapa frontal Front flange	15	Cuerpo bomba Pump housing
7	Junta antiextrusión Anti-extrusion gasket	16	Tapa posterior Back cover
8	Junta de compensación Compensation gasket	17	Tornillos Screws
9	Conjunto cojinete apoyo Bearing assembly	18	Arandelas Washers

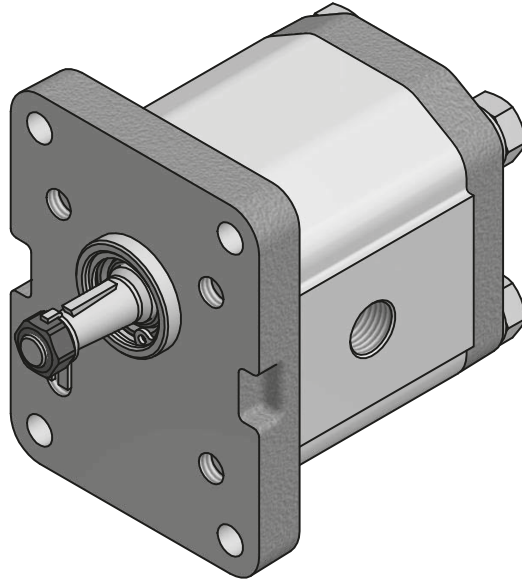

Caudal bomba <i>Pump flow rate</i>	L/min. 1500 R.P.M. (US. GPM 1500 RPM)	1,5 (0,40)	3 (0,79)	5 (1,32)	7,5 (1,98)	10 (2,64)
Cilindrada <i>Displacement</i>	cm ³ /v - cc/rev (in ³ /rev)	1 (0,06)	2 (0,12)	3,3 (0,20)	5 (0,31)	6,6 (0,40)
Presión máx. continua en <i>Cont. max. pressure</i>	bar (PSI)	275 (3990)		240 (3480)	185 (2685)	135 (1960)
Presión máx. inter 5 seg. max. <i>Intermittent max. pressure</i>	bar (PSI)	300 (4350)		275 (3990)	200 (2900)	150 (2175)
R.P.M. a presión continua <i>R.P.M. at cont. pressure</i>		5.000		4.000	3.000	
R.P.M. máximas <i>Max. R.P.M.</i>		6.000		5.000	4.000	3.000
Mínimas R.P.M. según presión <i>Min. R.P.M. at given pressures</i>	100 bar (1450 PSI)	1.000		750	500	
	175 bar (2540 PSI)	1.500	1.250		1.000	—
	250 bar (3625 PSI)	2.000	1.750	1.500	—	—
	300 bar (4350 PSI)	3.000	2.000	—	—	—
Aceite recomendado <i>Fluid to be used</i>		ISO 6743 tipo HM, HV ó HG				
Viscosidad <i>Viscosity range</i>		ISO 3448 cat. VG32-VG46				
Grado de limpieza del aceite <i>Recommended fluid cleanliness</i>		19/16 s/. ISO 4406 ó RP70H				
Temperatura de trabajo del aceite <i>Oil temperature</i>		-20°C... +80°C -4°F... +176°F				
Depresión máximo en aspiración <i>Max. suction depression</i>		< 0,3 bar				

CONEXIONES TIPO R

ROQUETHYDRAULICS, S.L. recomienda utilizar implantaciones roscadas cilíndricas: con cierre por arista de estanqueidad, junta plana o junta tórica. (Ver normas: DIN 3852, ISO1179, ISO 9974 y ISO 6149). No se recomienda utilizar otras implantaciones tipo cónicas, etc. A continuación se detallan los pares de apriete para implantaciones roscadas cilíndricas.

CONNECTION TYPES R

ROQUETHYDRAULICS, S.L. recommends to use threaded fittings with parallel threads: with sealing face, with flat seal or with o-ring seal (Standards: DIN 3852, ISO1179, ISO 9974 y ISO6149). It is not recommended to use conic type fittings, etc. Guide for tightening torques for threaded fittings with parallel threads.

PAR DE APRIETE / ASSEMBLY TORQUE

Rosca (ISO 228-1) Thread Size (ISO 228-1)	Par de apriete min. (Nm) Assembly Torque min. (Nm)	Par de apriete máx. (Nm) Assembly Torque max. (Nm)
1/8" G	20	25
1/4" G	50	55
3/8" G	80	90
1/2" G	100	100
3/4" G	200	220
1" G	380	420

ACCIONAMIENTO DE LAS BOMBAS

Deben utilizarse acoplamiento entre bomba y accionamiento que eviten la transmisión de esfuerzos tanto axiales como laterales. Las bombas en su configuración estandar no admiten este tipo de esfuerzos, causando una disminución rápida de su vida útil.

PUMP DRIVING DEVICES

It must be used a driving device to avoid the transmission of axial and radial loads to the axis of the pump. Standard flanges and pumps are not designed to handle this loads and this causes a reduction of its working life.

Gráfico de caudales, rendimientos y potencias según cilindrada Flow, performance and power chart according to displacement

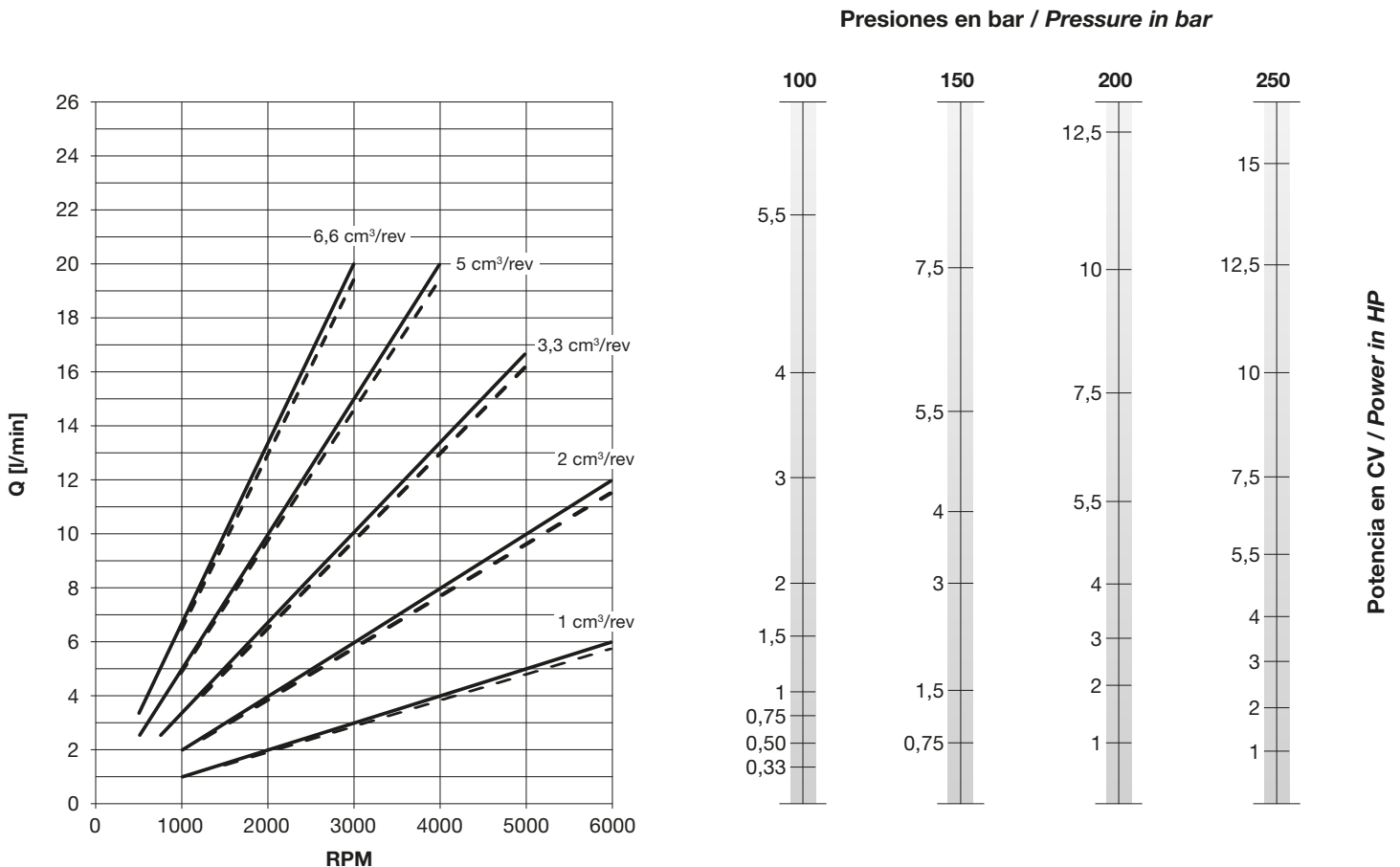

NOTA: Estos diagramas han sido obtenidos con un aceite de viscosidad VG 46 y una temperatura de 50°C.

NOTE: These results have been obtained with VG 46 viscosity oil and at 50 deg. C (122°F).

Sistema de codificación	1	L0	3	D	E	10	R	/	V	42	T***	-***	Coding system
-------------------------	---	----	---	---	---	----	---	---	---	----	------	------	---------------

Tipo / Type	
1	Sin polea / Without pulley
2	Con polea / With pulley

Modelo / Model	
L0	Simple / Simple
LQ	Múltiple / Multiple (L0+L0)
LP	Múltiple / Multiple (L0+M)

Caudal bomba a 1500 rpm y 0 bar Pump flow rate at 1500 rpm and 0 bar	
Ver hoja técnica / See technical data	

Sentido de giro / Rotation direction	
D	Derecha / Clockwise
I	Izquierda / Counterclockwise
R	Reversible / Reversible

Forma eje motriz / Drive shaft form	
B-C-E-H-J-Z	

Tipo polea / Pulley type	
P-R	

Código / Code

Variantes con válvulas / Alternatives with valves	
---	--

VA	Válvula de aspiración - retención / Check valve
----	---

Válvula limitadora / Relief valve	
-----------------------------------	--

Modelo precintable y taraje estándar / Tamper-proof sealable model and standard set pressure	
Rango de taraje / Pressure range	
V11	Tarada a / Set at 80 bar (5-80 bar)
V12	Tarada a / Set at 160 bar (85-175 bar)
V13	Tarada a / Set at 200 bar (180-250 bar)

Modelo con precinto y taraje específico / Tamper-proof sealed model and specific set pressure	
Rango de taraje / Pressure range	
V41T***	5-80 bar
V42T***	85-175 bar
V43T***	180-250 bar

En la válvula limitadora con precinto, los caracteres *** se deben sustituir por la presión de taraje (3 dígitos) de la válvula limitadora.

In tamper-proof sealed model, the signs *** have to be replaced by the set pressure (3 numbers) of the relief valve.

Ejemplo / Example 1: 1L03DE10R/V41T060

Ejemplo / Example 2: 1L07,5DE10R/V12

Formas conexión tomas / Port connection forms	
---	--

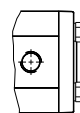

R

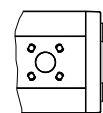

F

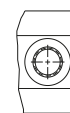

S

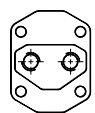

T

Tipo de tapa / Fixing flange	
------------------------------	--

01-09-10-22-27

Tipos de eje motriz disponibles / Available drive shaft forms

Eje forma B / Shaft form B

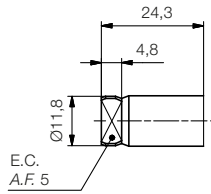

Máx. par de arrastre
Max. driving torque 25Nm

Eje forma C / Shaft form C

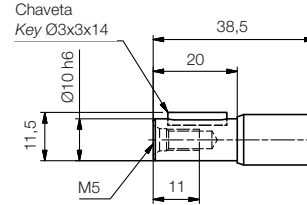

Máx. par de arrastre
Max. driving torque 25Nm

Eje forma E / Shaft form E

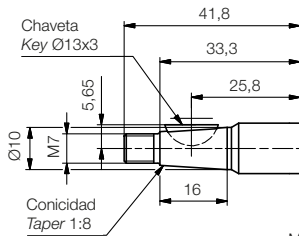

Máx. par de arrastre
Max. driving torque 30Nm

Eje forma H / Shaft form H

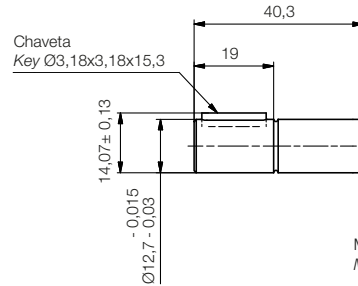

Máx. par de arrastre
Max. driving torque 30Nm

Eje forma J / Shaft form J

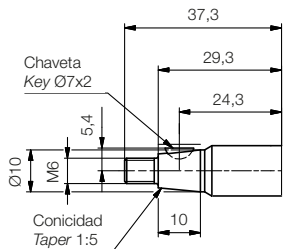

Máx. par de arrastre
Max. driving torque 26Nm

Eje forma Z / Shaft form Z

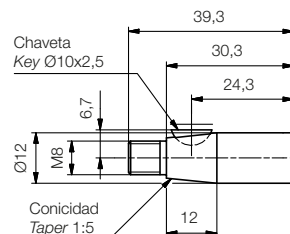

Máx. par de arrastre
Max. driving torque 40Nm

Formas de conexión de tomas disponibles / Available port connection forms

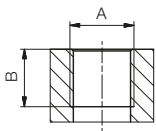

Tomas R / R Ports	1 sentido de rotación / 1 rotation direction				Reversible	
	Aspiración / Suction		Presión / Pressure		A	B
	A	B	A	B		
Caudal / Flow (1500 rpm)						
1,5 l/min ... 5 l/min	3/8" BSP	15	1/4" BSP	15	3/8" BSP	15
7,5 l/min ... 10 l/min	1/2" BSP	15	3/8" BSP	15	1/2" BSP	15

Dimensiones según ISO 1179-1 / Dimensions according to ISO 1179-1

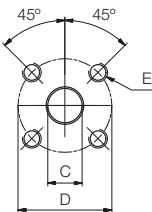

Tomas F / F Ports	1 sentido de rotación / 1 rotation direction					
	Aspiración / Suction			Presión / Pressure		
	C	D	E	C	D	E
Caudal / Flow (1500 rpm)						
1,5 l/min ... 10 l/min	14	30	M6x10	11	30	M6x10

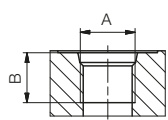

Tomas S / S Ports	1 sentido de rotación / 1 rotation direction			
	Aspiración / Suction		Presión / Pressure	
	A	B	A	B
Caudal / Flow (1500 rpm)				
1,5 l/min ... 10 l/min	3/4"-16 UNF	15	9/16"-18 UNF	13

Dimensiones según ISO 11926-1 / Dimensions according to ISO 11926-1

Tipos de tapas frontales disponibles / Available front flanges types

Tapa tipo 01 / Front flange type 01

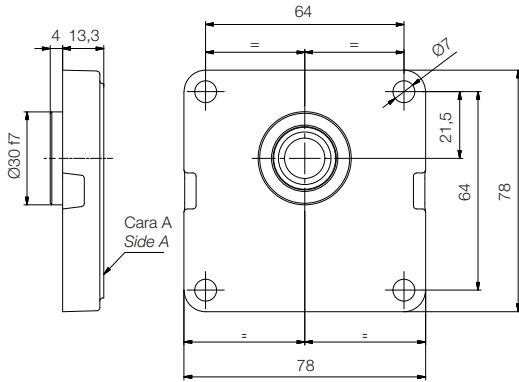

Tapa tipo 22 / Front flange type 22

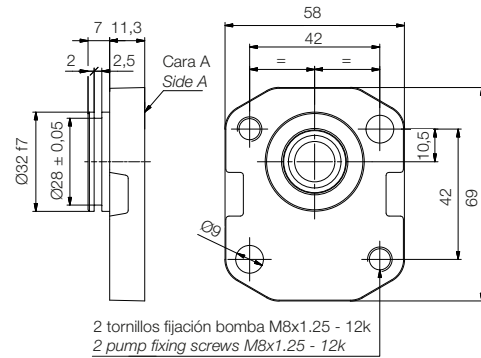

Tapa tipo 09 / Front flange type 09

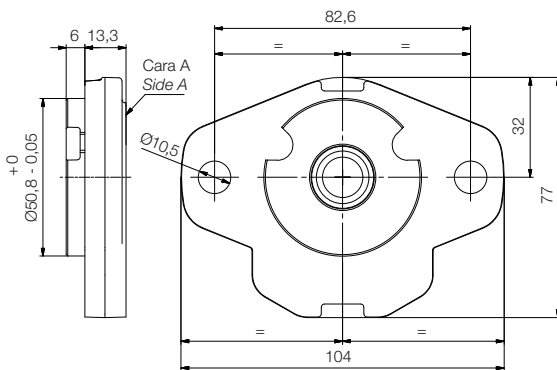

Tapa tipo 27 / Front flange type 27

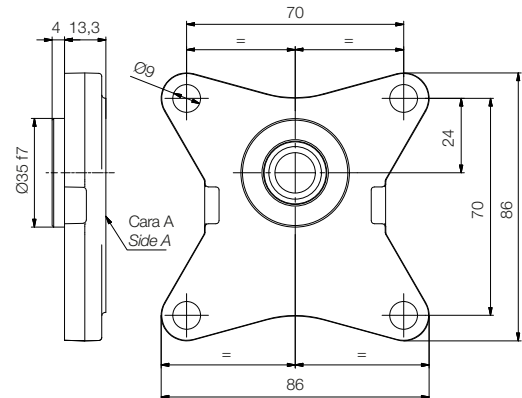

Tapa tipo 10 / Front flange type 10

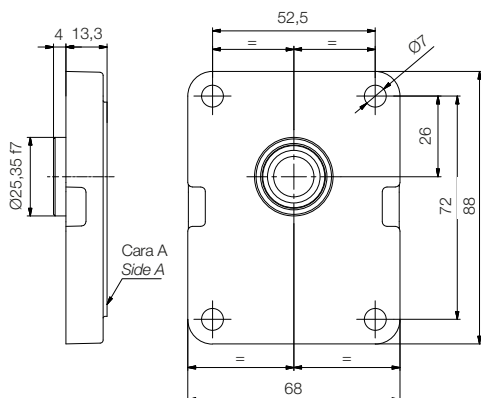

NOTA: La longitud del eje motriz varía en función del grosor de la tapa frontal.

NOTE: The useful length of the drive shaft varies depending on the front flange thickness.

Ejemplo: Combinación de un eje tipo C con una tapa tipo 01
Example: Combination of a C type shaft with a 01 type front flange

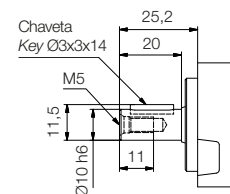

Tapa tipo 01 / Front flange type 01



Eje forma C / Shaft form C

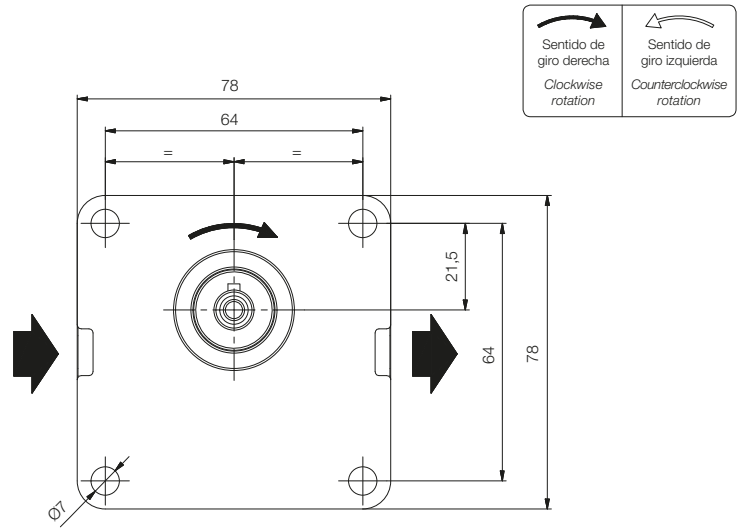
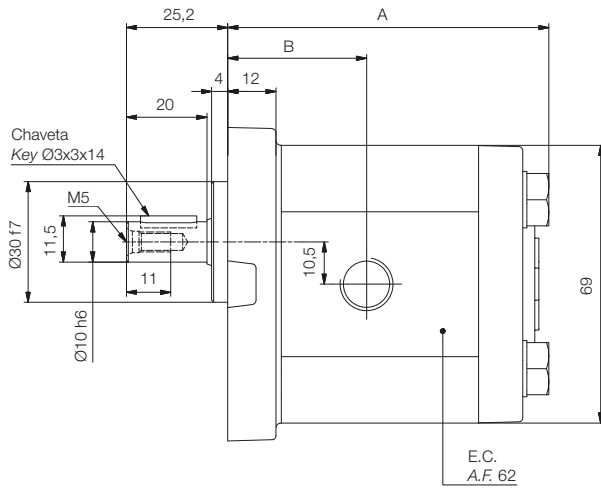

Eje forma B / Shaft form B

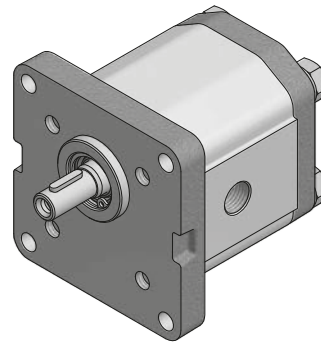
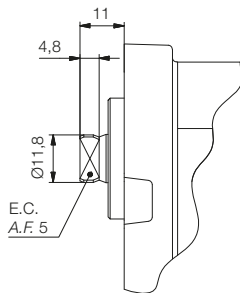

Referencia Reference	Cilindrada cm ³ /rev Displacement cm ³ /rev	A	B	Peso kg Weight kg
1L01,5D▲01R	1	67,8	31	1,35
1L03D▲01R	2	72,8	31	1,44
1L05D▲01R	3,3	79,8	34,5	1,52
1L07,5D▲01R	5	88,3	37,5	1,64
1L010D▲01R	6,6	96,8	42,8	1,77

▲ Forma de eje / Shaft form.

NOTA: Para dimensiones y tipos de tomas disponibles de bombas de giro derecha (D), izquierda (I) o reversible (R), consultar página 8.
NOTE: For dimensions and available port types of clockwise (D), counterclockwise (I) or reversible (R) rotation pumps, see page 8.

Tapa tipo 09 / Front flange type 09

Eje forma H / Shaft form H

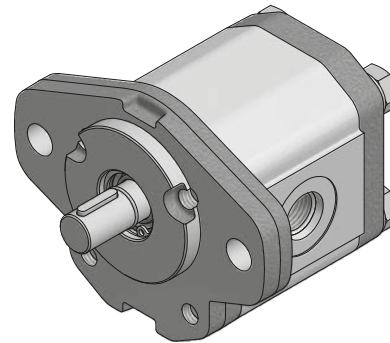
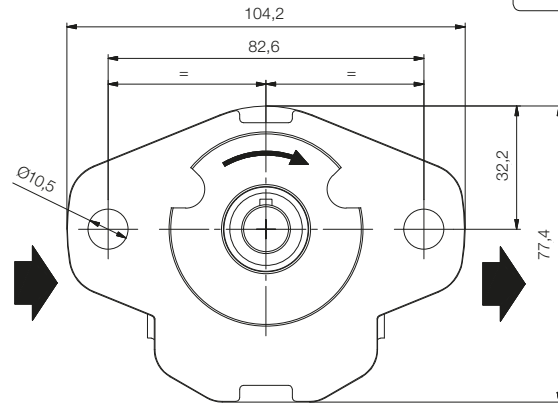
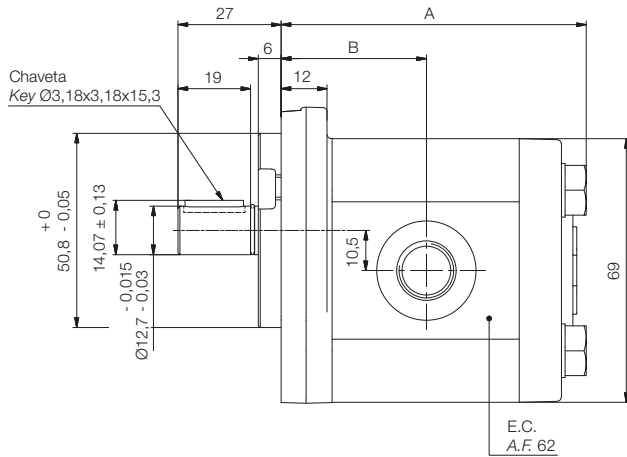
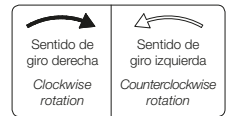

Referencia Reference	Cilindrada cm ³ /rev Displacement cm ³ /rev	A	B	Peso kg Weight kg
1L01,5DH09S	1	67,8	32	1,38
1L03DH09S	2	72,8	35	1,47
1L05DH09S	3,3	79,8	38	1,55
1L07,5DH09S	5	88,3	42	1,67
1L010DH09S	6,6	96,8	47	1,79

NOTA: Para dimensiones y tipos de tomas disponibles de bombas de giro derecha (D), izquierda (I) o reversible (R), consultar página 8.
NOTE: For dimensions and available port types of clockwise (D), counterclockwise (I) or reversible (R) rotation pumps, see page 8.

Tapa tipo 10 / Front flange type 10



Eje forma E / Shaft form E

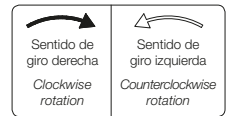
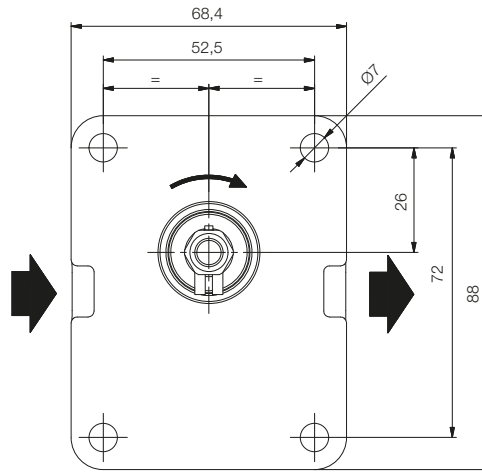
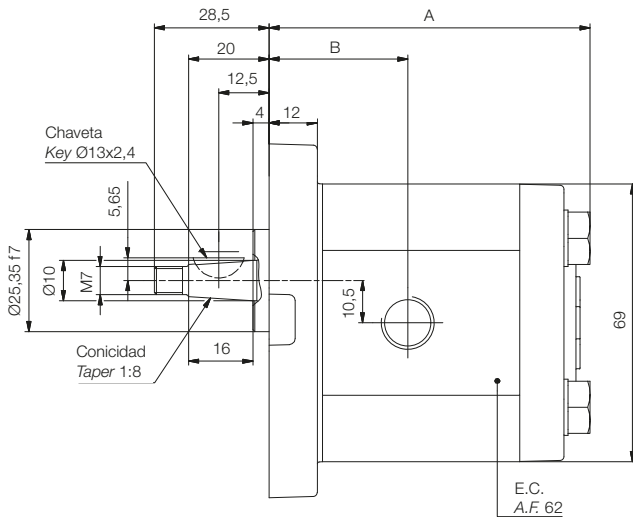

Eje forma C / Shaft form C

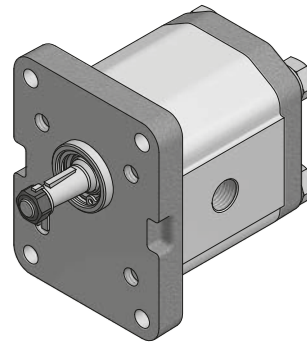
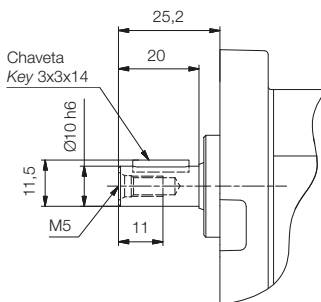

Referencia Reference	Cilindrada cm ³ /rev Displacement cm ³ /rev	A	B	Peso kg Weight kg
1L01,5D▲10R	1	67,8	31	1,38
1L03D▲10R	2	72,8	31	1,47
1L05D▲10R	3,3	79,8	34,5	1,55
1L07,5D▲10R	5	88,3	37,5	1,67
1L010D▲10R	6,6	96,8	42,8	1,79

▲ Forma de eje / Shaft form.

NOTA: Para dimensiones y tipos de tomas disponibles de bombas de giro derecha (D), izquierda (I) o reversible (R), consultar página 8.
NOTE: For dimensions and available port types of clockwise (D), counterclockwise (I) or reversible (R) rotation pumps, see page 8.

Tapa tipo 22 / Front flange type 22

Eje forma J / Shaft form J

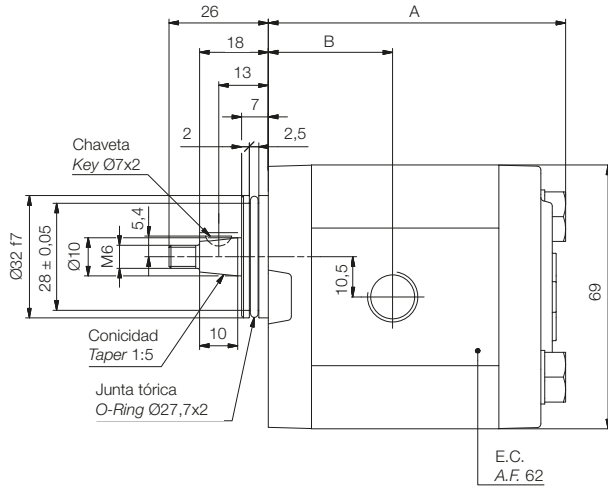

Par de apriete tornillos fijación bomba
 Pump fixing screws torque 30-40Nm

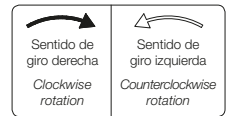
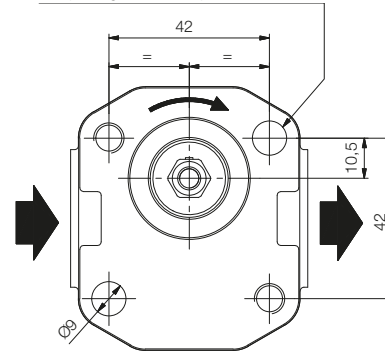

Eje forma B / Shaft form B

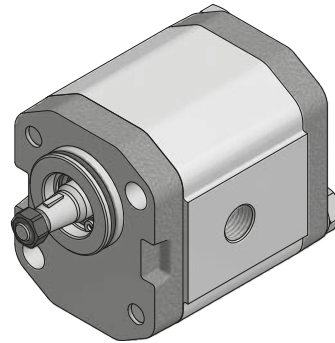
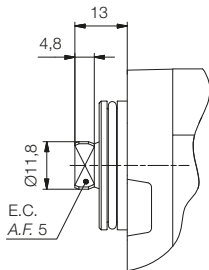

Referencia Reference	Cilindrada cm ³ /rev Displacement cm ³ /rev	A	B	Peso kg Weight kg
1L01,5D▲22R	1	65,8	29	1,04
1L03D▲22R	2	70,8	29	1,13
1L05D▲22R	3,3	77,8	32,5	1,21
1L07,5D▲22R	5	86,3	35,5	1,33
1L010D▲22R	6,6	94,8	40,8	1,46

▲ Forma de eje / Shaft form.

NOTA: Para dimensiones y tipos de tomas disponibles de bombas de giro derecha (D), izquierda (I) o reversible (R), consultar página 8.
NOTE: For dimensions and available port types of clockwise (D), counterclockwise (I) or reversible (R) rotation pumps, see page 8.

Tapa tipo 27 / Front flange type 27



Eje forma Z / Shaft form Z

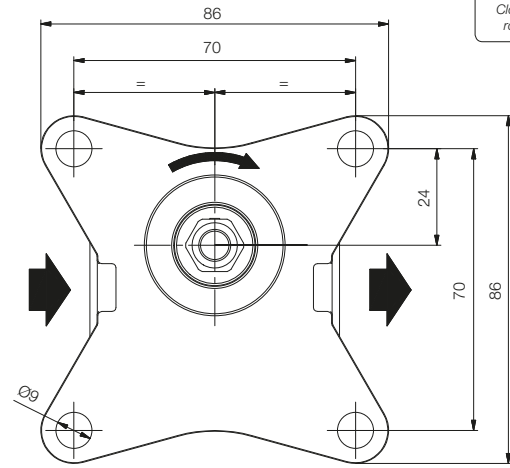
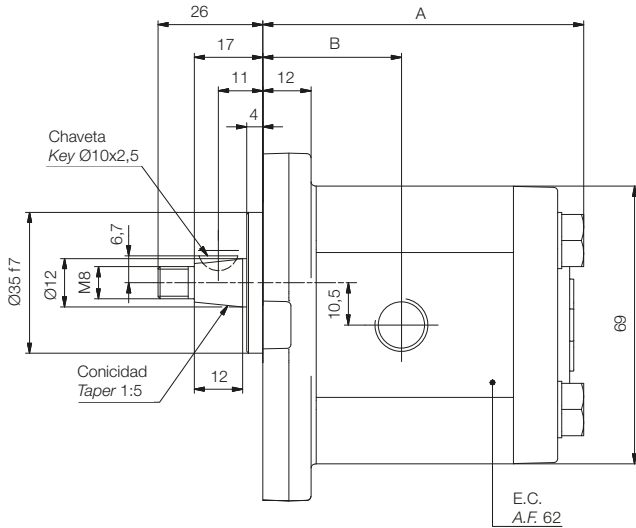

Eje forma C / Shaft form C

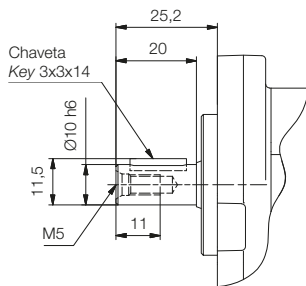

Eje forma B / Shaft form B

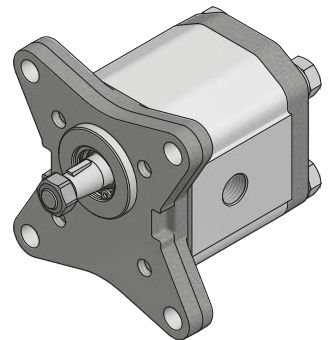
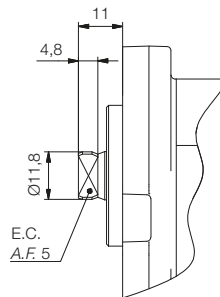

Referencia Reference	Cilindrada cm ³ /rev Displacement cm ³ /rev	A	B	Peso kg Weight kg
1L01,5D▲27R	1	67,8	31	1,20
1L03D▲27R	2	72,8	31	1,29
1L05D▲27R	3,3	79,8	34,5	1,37
1L07,5D▲27R	5	88,3	37,5	1,49
1L010D▲27R	6,6	96,8	42,8	1,61

▲ Forma de eje / Shaft form.

NOTA: Para dimensiones y tipos de tomas disponibles de bombas de giro derecha (D), izquierda (I) o reversible (R), consultar página 8.
NOTE: For dimensions and available port types of clockwise (D), counterclockwise (I) or reversible (R) rotation pumps, see page 8.

Tapa tipo 10 / Front flange type 10

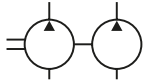

Eje forma E / Shaft form E

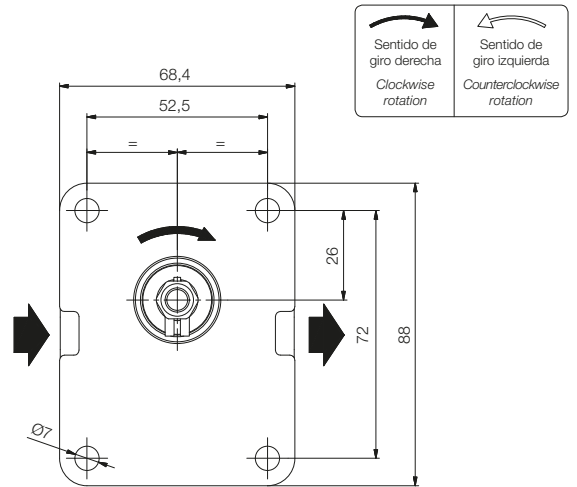
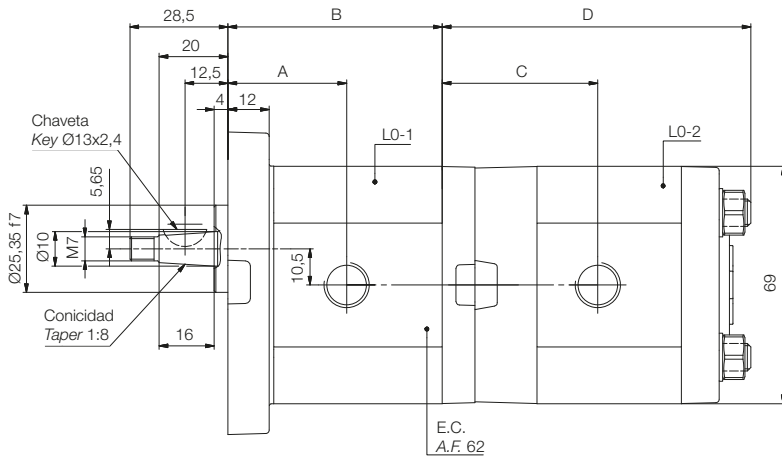

Eje forma C / Shaft form C

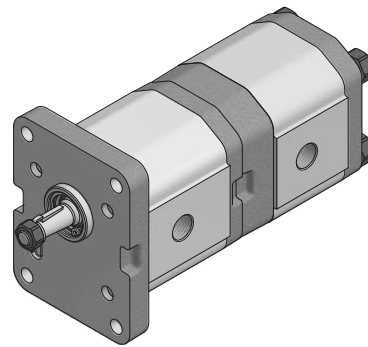
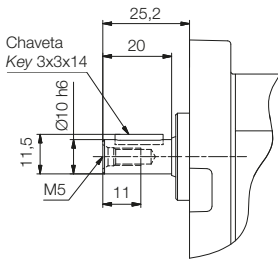

Para montajes de bombas de más de dos etapas, consultar con el departamento comercial. Máximo par de arrastre entre bombas 25 Nm.
For more than two stages pump assemblies, contact the sales department. Maximum driving torque between stages 25 Nm.

La tabla siguiente hace referencia a la etapa frontal (L0-1) de la bomba múltiple LQ.
The following table refers to the front stage (L0-1) of the LQ multiple pump.

Referencia Reference	Cilindrada cm ³ /rev Displacement cm ³ /rev	A	B	Peso kg Weight kg
1LQ1,5-■D▲10R	1	31,0	50,3	1,2
1LQ3-■D▲10R	2	31,0	55,3	1,3
1LQ5-■D▲10R	3,3	34,5	62,3	1,4
1LQ7,5-■D▲10R	5	37,5	70,8	1,5
1LQ10-■D▲10R	6,6	42,8	79,3	1,6

■ Caudal etapa posterior (L0-2). Ver tabla / Rear stage flow (L0-2). See table.
▲ Forma de eje / Shaft form.

La tabla siguiente hace referencia a la etapa posterior (L0-2) de la bomba múltiple LQ.
The following table refers to the rear stage (L0-2) of the LQ multiple pump.

■	Cilindrada cm ³ /rev Displacement cm ³ /rev	C	D	Peso kg Weight kg
1,5	1	41,7	84,7	1,2
3	2	41,7	89,7	1,3
5	3,3	45,2	96,7	1,4
7,5	5	48,2	105,2	1,5
10	6,6	53,5	114,7	1,6

Ejemplo referencia comercial bomba LQ Part number example LQ pump

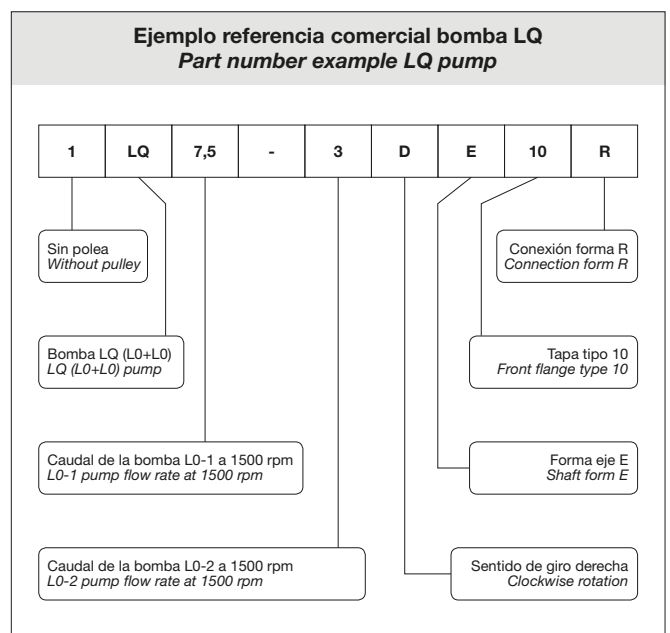

NOTA: Para dimensiones y tipos de tomas disponibles de bombas de giro derecha (D), izquierda (I) o reversible (R), consultar página 8.
NOTE: For dimensions and available port types of clockwise (D), counterclockwise (I) or reversible (R) rotation pumps, see page 8.

Tapa tipo 10 / Front flange type 10

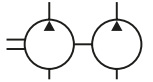

Eje forma E / Shaft form E

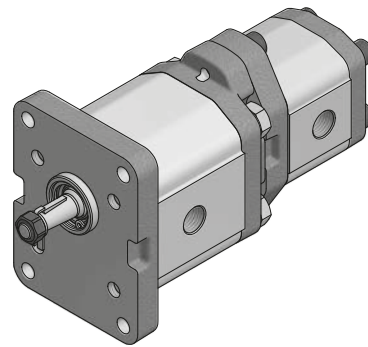
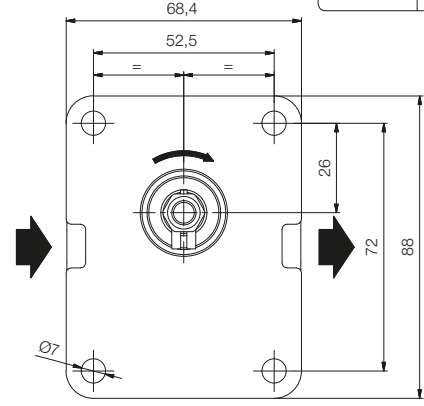
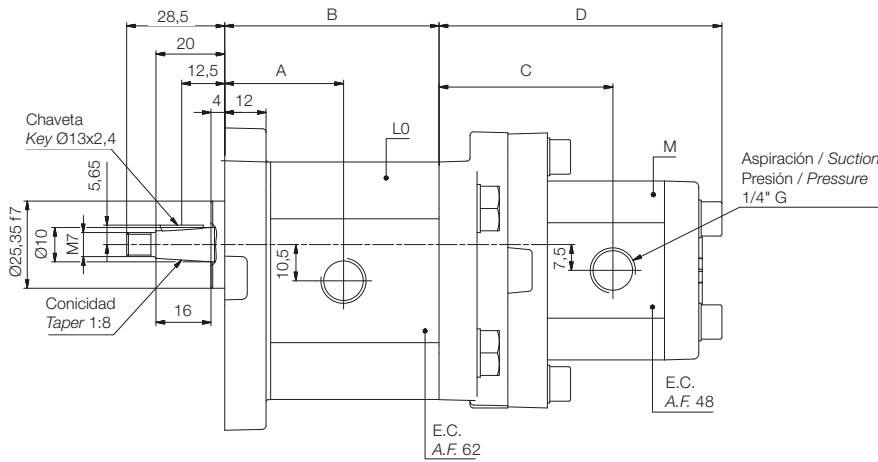
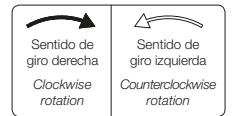

Máximo par de arrastre entre bombas 5 Nm / Maximum driving torque between stages 5 Nm.

La tabla siguiente hace referencia a la etapa frontal (L0) de la bomba múltiple LP.
The following table refers to the front stage (L0) of the LP multiple pump.

Referencia Reference	Cilindrada cm ³ /rev Displacement cm ³ /rev	A	B	Peso kg Weight kg
1LP1,5-■D▲10R	1	31,0	50,3	1,2
1LP3-■D▲10R	2	31,0	55,3	1,3
1LP5-■D▲10R	3,3	34,5	62,3	1,4
1LP7,5-■D▲10R	5	37,5	70,8	1,5
1LP10-■D▲10R	6,6	42,8	79,3	1,6

■ Caudal etapa posterior (M). Ver tabla / Rear stage flow (M). See table.
▲ Forma de eje / Shaft form.

La tabla siguiente hace referencia a la etapa posterior (M) de la bomba múltiple LP.
The following table refers to the rear stage (M) of the LP multiple pump.

■	Cilindrada cm ³ /rev Displacement cm ³ /rev	C	D	Peso kg Weight kg
0,5	0,33	46,5	74,0	0,55
0,75	0,5	47,5	76,0	0,60
1	0,66	48,0	78,0	0,60
1,25	0,83	48,0	80,0	0,65
1,5	1	50,5	82,0	0,70
2	1,33	50,5	86,0	0,70

Ejemplo referencia comercial bomba LP Part number example LP pump

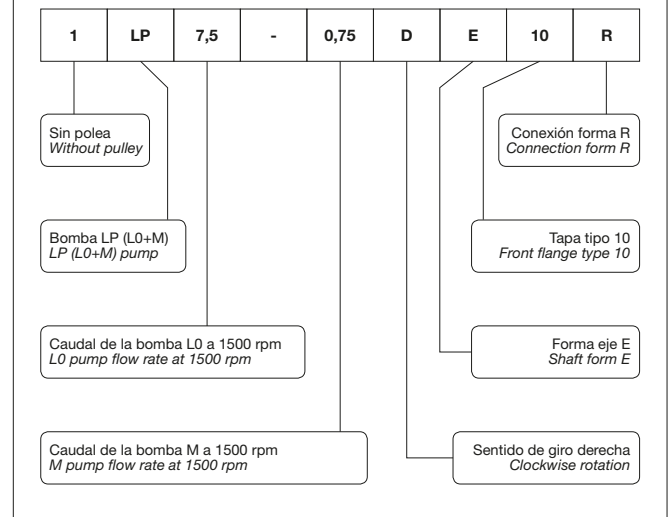

NOTAS: Bomba L0: para dimensiones y tipos de tomas disponibles de bombas de giro derecha (D), izquierda (I) o reversible (R), consultar página 8.
Bomba M: para dimensiones y tipos de toma disponibles consultar catálogo M.
NOTES: L0 pump: for dimensions and available port types of clockwise (D), counterclockwise (I) or reversible (R) rotation pumps, see page 8.
M pump: for dimensions and port types see M catalog.

Tapa tipo 22 / Front flange type 22

Eje forma E / Shaft form E

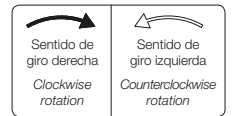
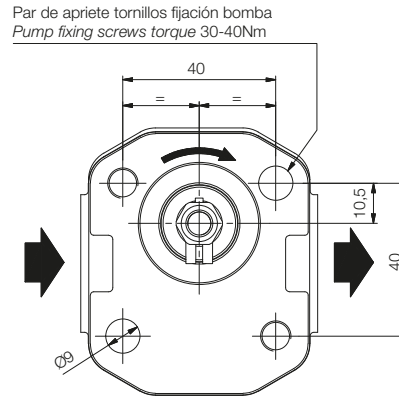
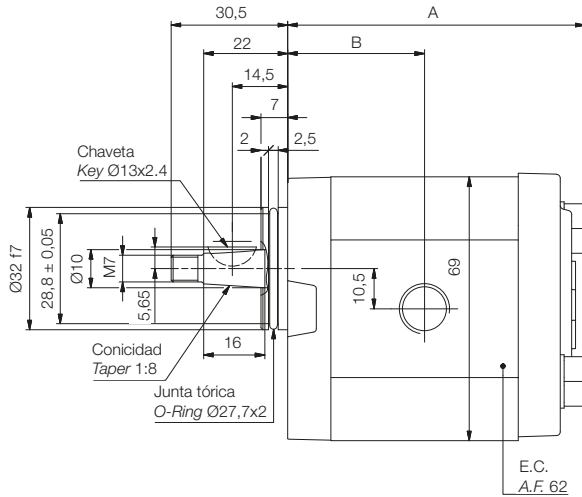

NOTA 1: El modelo de bomba L0F solo está disponible con tapa frontal tipo 22.

NOTE 1: The pump model L0F is only available with front flange type 22.

NOTA 2: Consultar disponibilidad y opciones de configuración con el departamento comercial.

NOTE 2: Contact the sales department for availability and configuration options.

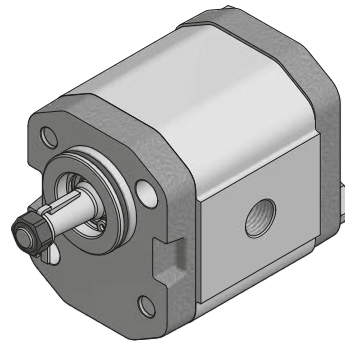

Referencia Reference	Cilindrada cm ³ /rev Displacement cm ³ /rev	A	B	Peso kg Weight kg
1L0F1,5D▲22R	1	65,8	29,8	1,04
1L0F3D▲22R	2	70,8	32,3	1,13
1L0F5D▲22R	3,3	77,8	35,8	1,21
1L0F7,5D▲22R	5	86,3	40,1	1,33
1L0F10D▲22R	6,6	94,8	44,3	1,46

▲ Forma de eje / Shaft form.

NOTA: Para dimensiones y tipos de tomas disponibles de bombas de giro derecha (D), izquierda (I) o reversible (R), consultar página 8.
NOTE: For dimensions and available port types of clockwise (D), counterclockwise (I) or reversible (R) rotation pumps, see page 8.

Conexión con tomas T Port connection form T

Tapa posterior para bombas con tomas traseras
Back cover for pumps with rear ports

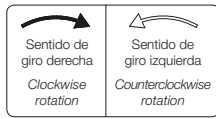
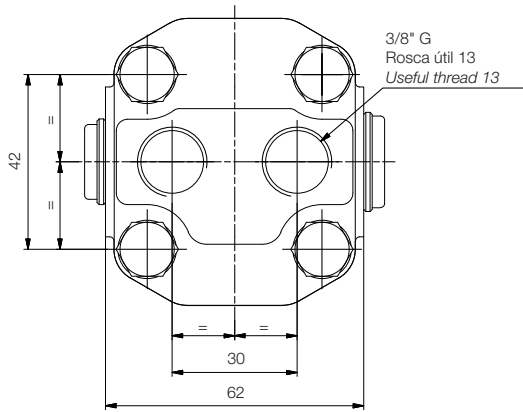

Tapa trasera para bombas reversibles Back cover for reversible pumps

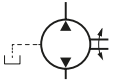
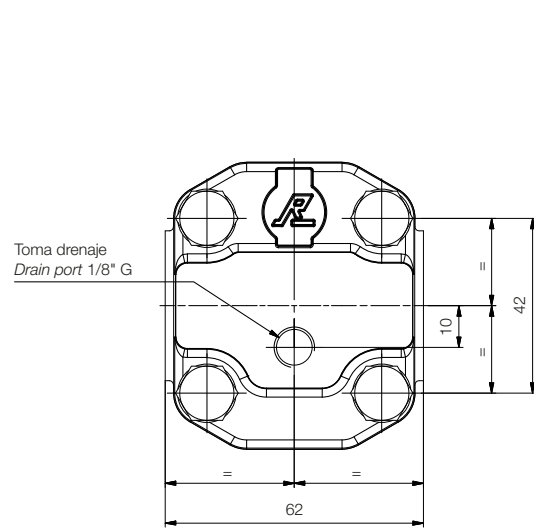

Tipos de polea / Types of pulley

Tipo P / Type P

Con correa tipo Z
With belt type Z

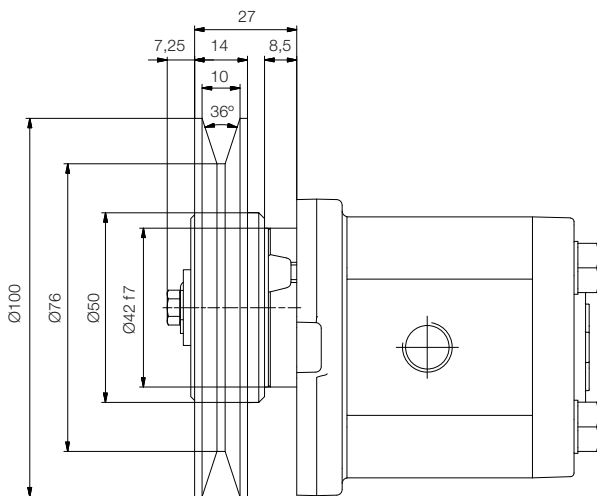

Tipo R / Type R

Con correa tipo A
With belt type A

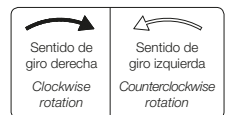
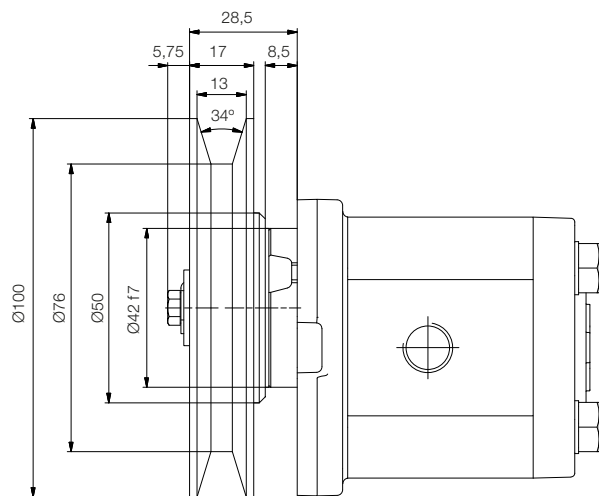

NOTA: Opción solo disponible con tapa tipo 01. Para medidas de fijación bomba ver página 9.
NOTE: Option only available with flange type 01. For pump fixing dimensions see page 9.

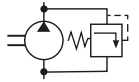

V - Válvula limitadora / V - Relief valve

Diagrama presión-caudal válvula limitadora según rango de taraje
Relief valve pressure-flow diagram depending on pressure range

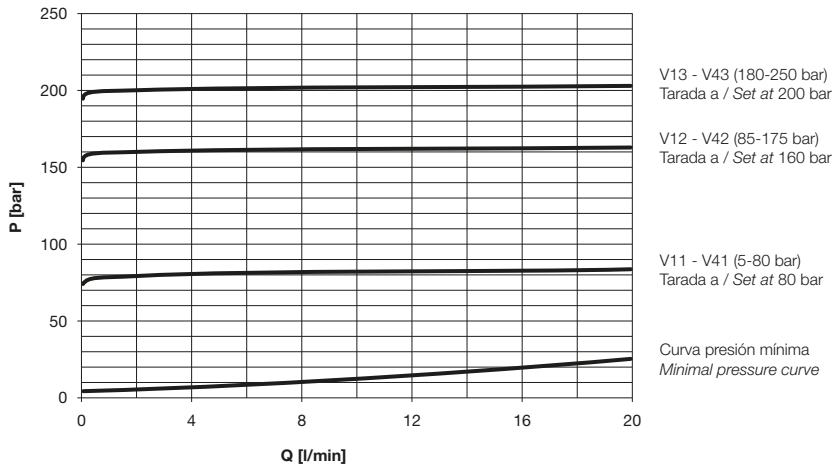

NOTA: Este gráfico ha sido obtenido con un aceite de viscosidad cinemática de 32cSt.
NOTE: The values shown in the above diagram have been obtained using a 32cSt kinematic viscosity oil.

Tapa tipo 10 / Flange type 10

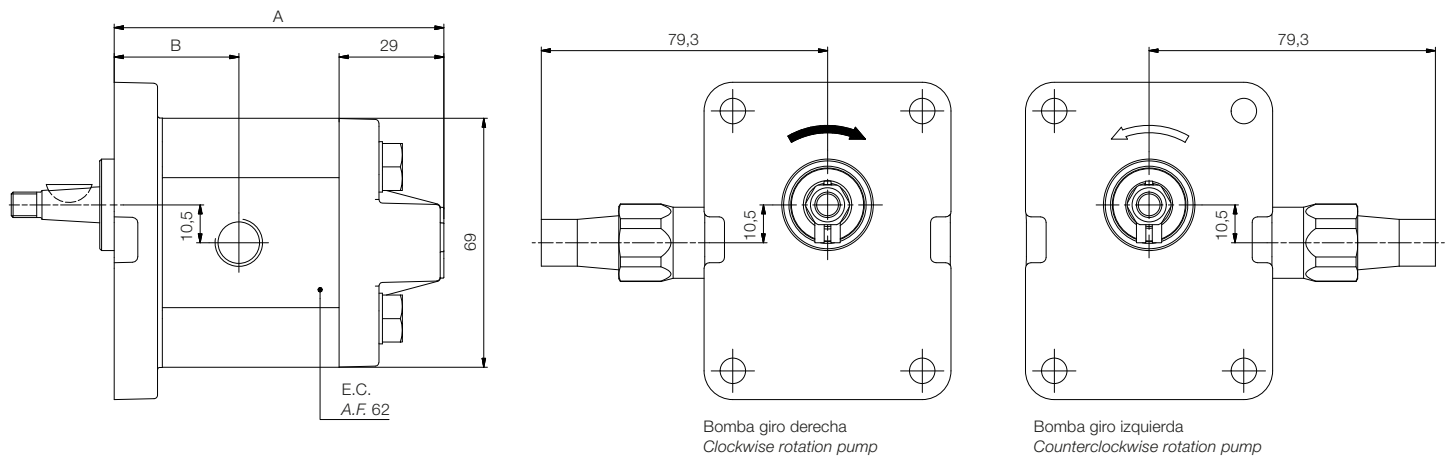
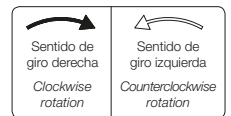

Referencia Reference	Cilindrada cm ³ /rev Displacement cm ³ /rev	A	B	Peso kg Weight kg
1L01,5DE10R/V ■	1	79,3	31	1,55
1L03DE10R/V ■	2	84,3	31	1,63
1L05DE10R/V ■	3,3	91,3	34,5	1,72
1L07,5DE10R/V ■	5	99,8	37,5	1,83
1L010DE10R/V ■	6,6	108,3	42,8	2,07

■ Modelo de válvula limitadora (ver página 7) / Relief valve model (see page 7).

NOTA: Esta bomba con válvula limitadora está disponible con cualquiera de las tapas y ejes que se representan en este catálogo, pero solo con cuerpos con tomas R. Consultar con el departamento comercial para otras opciones.

NOTE: This pump with relief valve is available with any fixing flange and shaft form shown in this catalogue, but only with pump housings with R ports. For other options, contact the sales department.

NOTA: Para dimensiones y tipos de tomas disponibles de bombas de giro derecha (D), izquierda (I) o reversible (R), consultar página 8.
NOTE: For dimensions and available port types of clockwise (D), counterclockwise (I) or reversible (R) rotation pumps, see page 8.

VA - Válvula de aspiración - retención / VA - Check valve



Diagrama presión-caudal válvula de aspiración - retención
Check valve pressure-flow diagram



NOTA: Este gráfico ha sido obtenido con un aceite de viscosidad cinemática de 32cSt.
NOTE: The values shown in the above diagram have been obtained using a 32cSt kinematic viscosity oil.

Tapa tipo 10 / Flange type 10

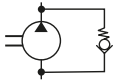
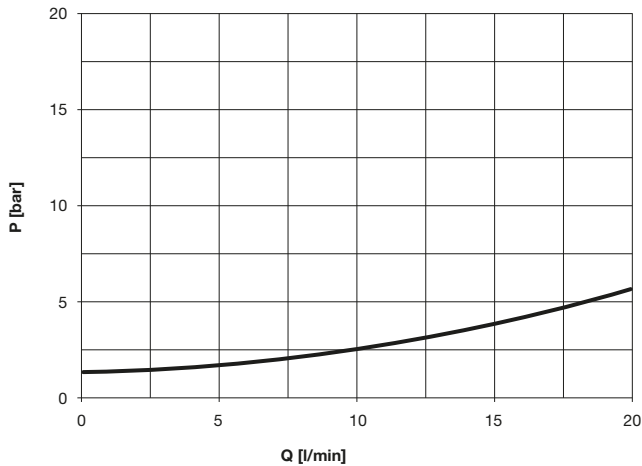
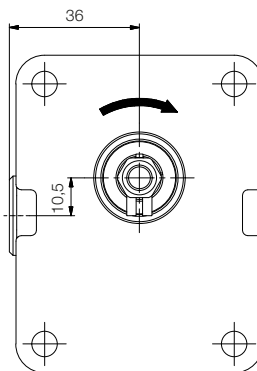
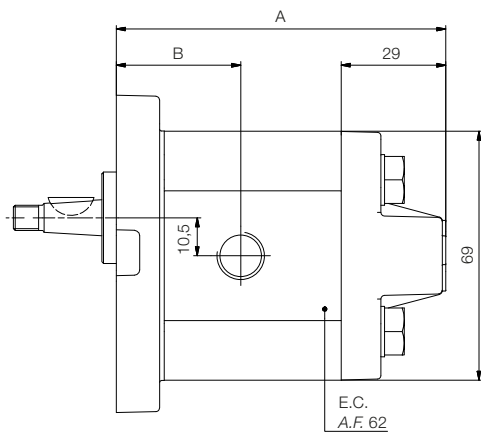
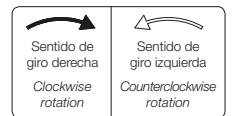

Bomba giro derecha
Clockwise rotation pump

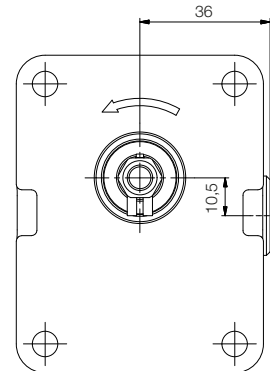

Bomba giro izquierda
Counterclockwise rotation pump

Referencia Reference	Cilindrada cm ³ /rev Displacement cm ³ /rev	A	B	Peso kg Weight kg
1L01,5DE10R/VA	1	79,3	31	1,49
1L03DE10R/VA	2	84,3	31	1,58
1L05DE10R/VA	3,3	91,3	34,5	1,66
1L07,5DE10R/VA	5	99,8	37,5	1,78
1L010DE10R/VA	6,6	108,3	42,8	2,02

NOTA: Esta bomba con válvula antirretorno está disponible con cualquiera de las tapas y ejes que se representan en este catálogo, pero solo con cuerpos con tomas R. Consultar con el departamento comercial para otras opciones.

NOTE: This pump with check valve is available with any fixing flange and shaft form shown in this catalogue, but only with pump housings with R ports. For other options, contact the sales department.

NOTA: Para dimensiones y tipos de tomas disponibles de bombas de giro derecha (D), izquierda (I) o reversible (R), consultar página 8.
NOTE: For dimensions and available port types of clockwise (D), counterclockwise (I) or reversible (R) rotation pumps, see page 8.

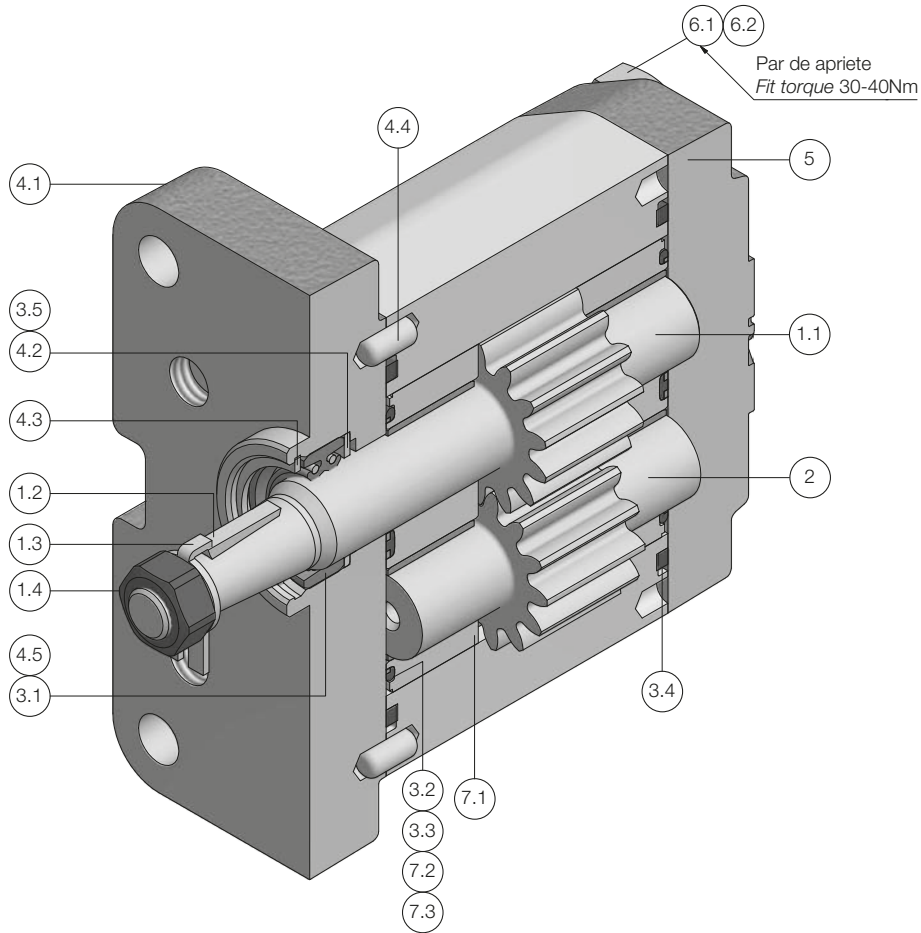

Nº de kit Kit number	Descripción Description	Piezas Parts
1	Kit eje motriz Drive shaft kit	
2	Eje conducido Driven shaft	
3	Kit juntas Seals kit	
4	Kit tapa delantera Front flange kit	

Nº de kit Kit number	Descripción Description	Piezas Parts
5	Tapa posterior Back cover	
6	Kit tornillos fijación Fixing screws kit	
7	Kit cojinetes apoyo Bearing assemblies kit	

NOTA: Consultar las referencias disponibles con el departamento comercial.
NOTE: For available references contact the sales department.

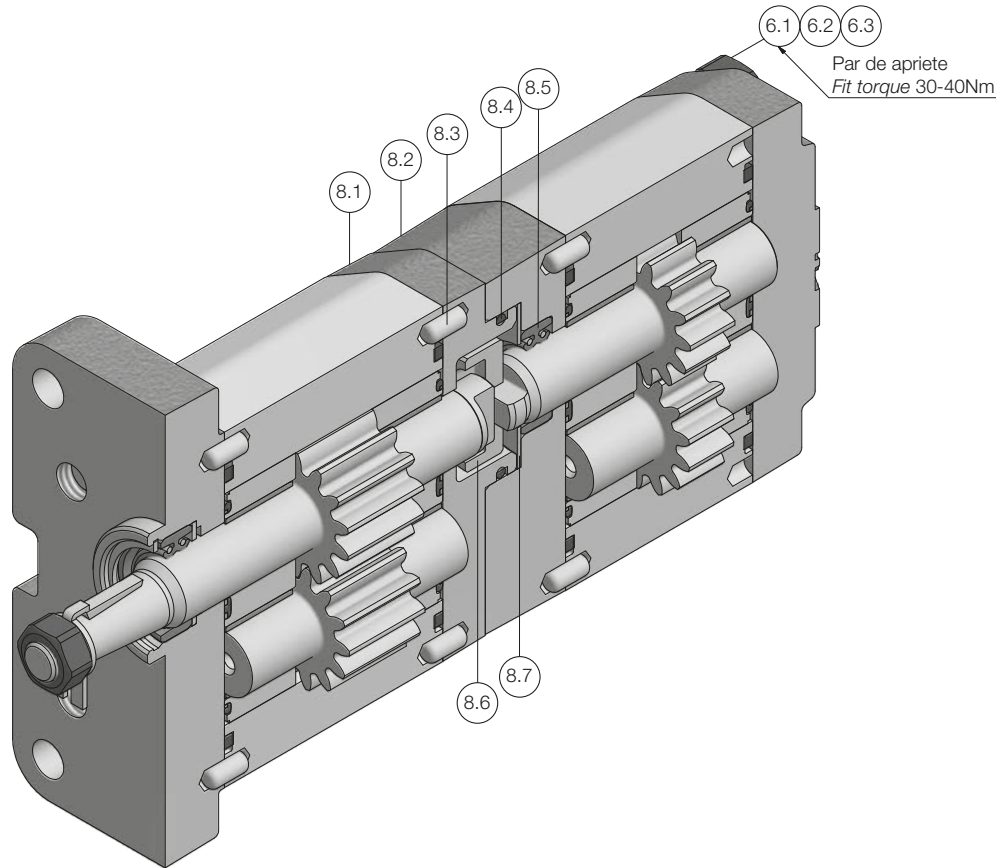

Nº de kit Kit number	Descripción Description	Piezas Parts
6	Kit espárragos fijación Fixing rods kit	

Nº de kit Kit number	Descripción Description	Piezas Parts
8	Kit tapas intermedias Intermediate flanges kit	

NOTA: Se puede crear una bomba doble LQ uniendo una bomba de referencia estándar y sufijo -SMP con una bomba estándar con eje tipo L y tapa frontal tipo 26. Se ofrece el kit de tapas intermedias y el kit del eje tipo L para poder transformar la bomba.

NOTE: A LQ double pump can be assembled from a pump with standard reference and suffix -SMP and a pump with shaft form L and front flange type 26. The intermediate flanges kit and the L shaft kit are offered in order to transform the pump.

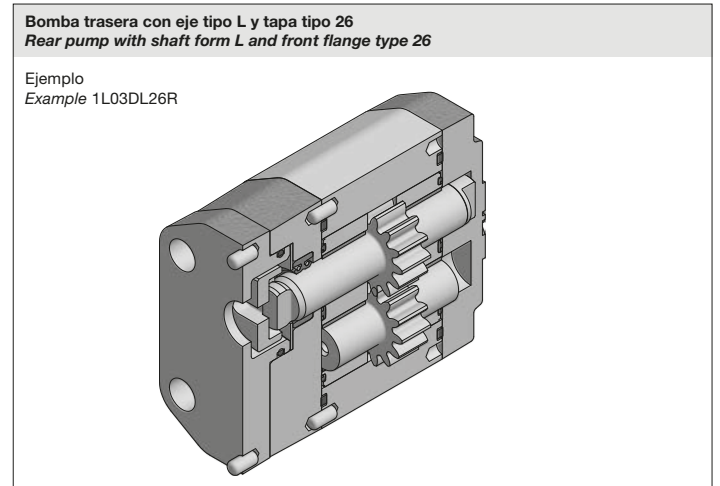
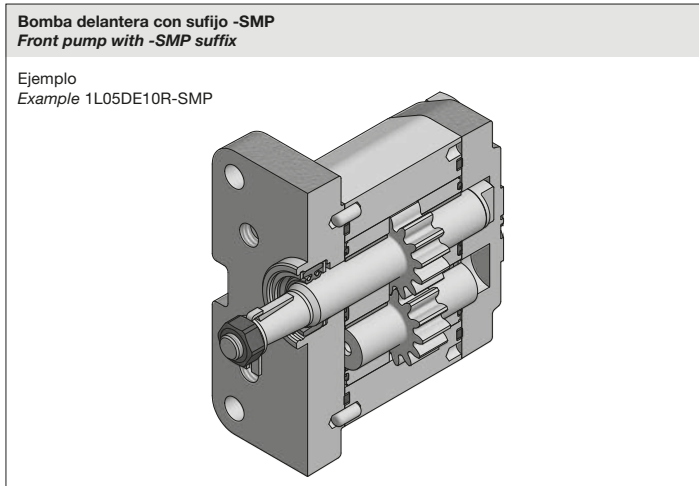

NOTA: Consultar las referencias disponibles con el departamento comercial. / **NOTE:** For available references contact the sales department.

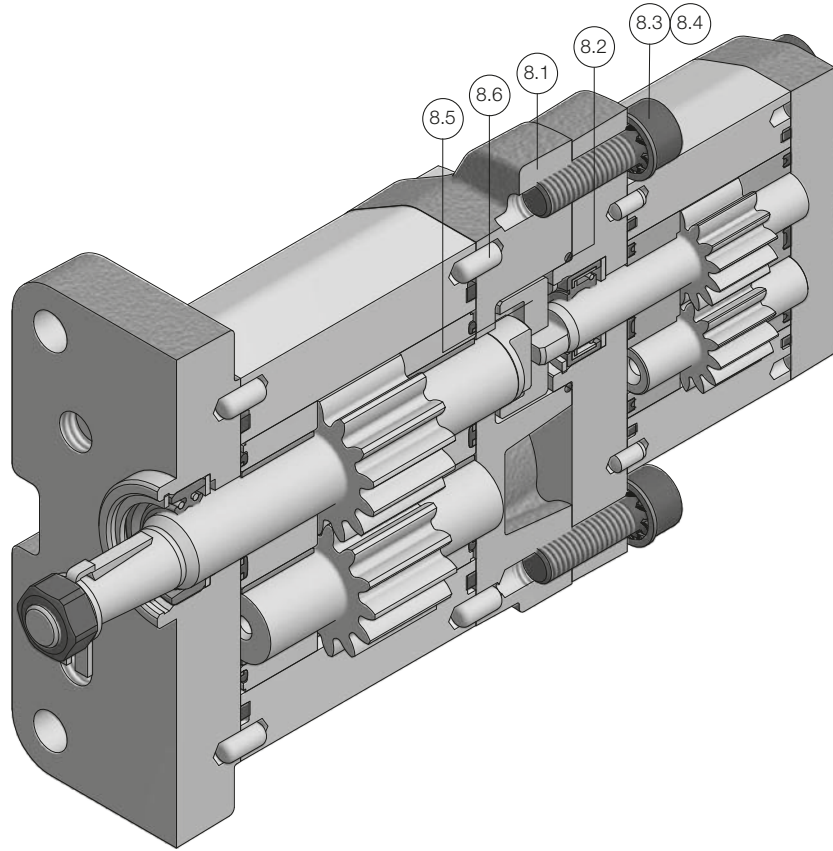

Nº de kit Kit number	Descripción Description	Piezas Parts
8	Kit tapa intermedia Intermediate flange kit	

NOTA: Se puede crear una bomba doble LP uniendo una bomba L0 de referencia estándar y sufijo -SMP, un kit de tapa intermedia y una bomba M estándar con eje tipo B y tapa frontal tipo 09.

NOTE: A LP double pump can be assembled from a L0 pump with standard reference and suffix -SMP, an intermediate flange kit and a standard M pump with shaft form B and front flange type 09.

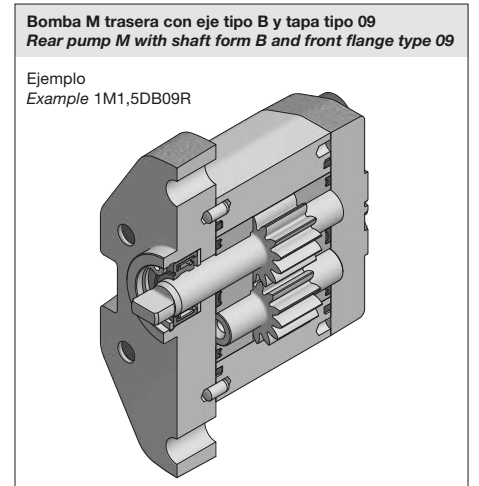
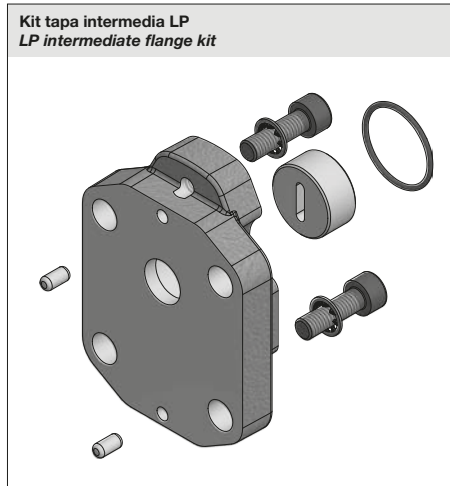
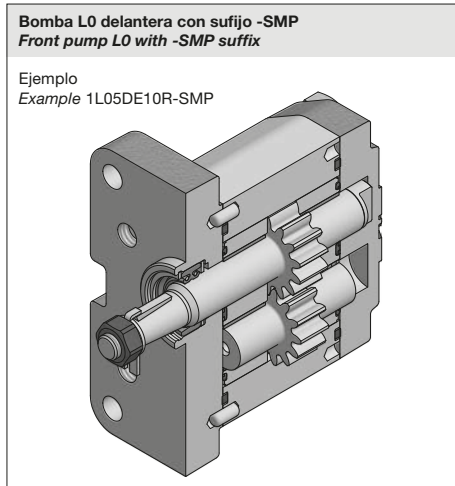

NOTA: Consultar las referencias disponibles con el departamento comercial. / **NOTE:** For available references contact the sales department.

Roquet
making moves
www.roquetgroup.com